

MALE END VIEW

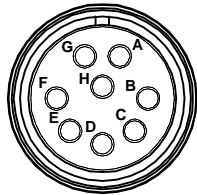

- A = PINK
- B = GRAY
- C = YELLOW
- D = GREEN
- E = BROWN
- F = WHITE
- G = BLUE
- H = RED

CONNECTOR
 TYPE/STYLE - MS 3116M
 SHELL SIZE - 12
 INSERT ARRANGEMENT - 8P

SPECIFICATIONS

CONTACT CARRIER MATERIAL	NEOPRENE
MOLDED HEAD MATERIAL/COLOR	PVC/BLACK
CONTACT MATERIAL/PLATING	COPPER ALLOY/GOLD
COUPLING NUT MATERIAL/PLATING	ALUMINUM ALLOY/OLIVE DRAB CHROMATE
MOLD SLEEVE	ALUMINUM/BLACK ANODIZED
RATED CURRENT [A]	4.9 A
RATED VOLTAGE [V]	300 V
OUTER JACKET MATERIAL/COLOR	PVC/GRAY
CONDUCTOR INSULATION MATERIAL	PVC
NUMBER OF CONDUCTORS	8x22 AWG
TEMPERATURE RATING	-40°C to +105°C (-40°F to +221°F)
PROTECTION CLASS	MEETS NEMA 1,3,4,6P AND IEC IP67,IP68
CONNECTOR TYPE	MIL-DTL-26482

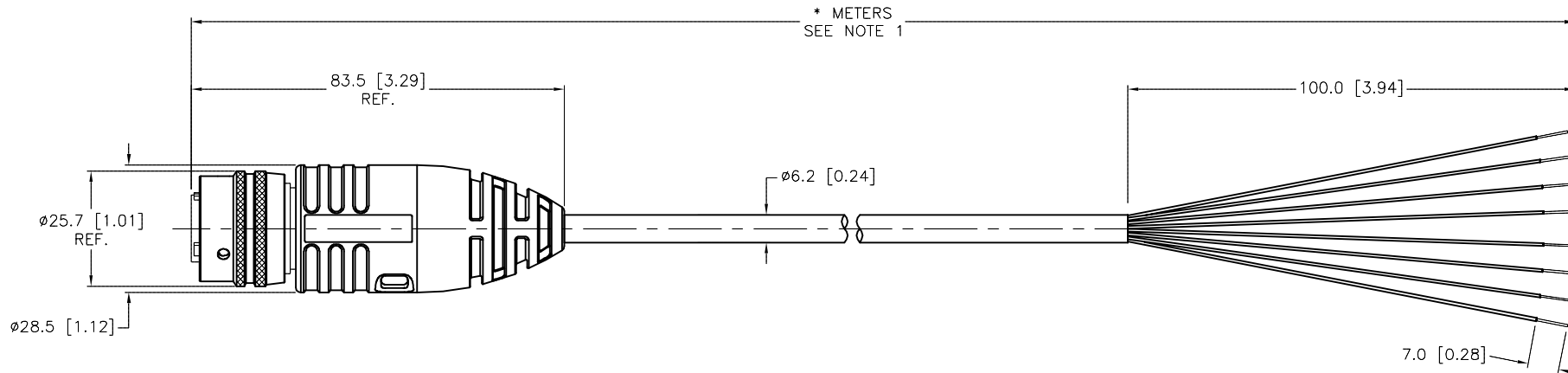

CABLE LENGTH	TOLERANCE*
ALL LENGTHS	+ 4% (OR 50mm) OF LENGTH - 0% (OR 0mm) OF LENGTH WHICHEVER IS GREATER
STRIP LENGTH	TOLERANCE*
0-7mm	±0.5mm
8-29mm	±1.0mm
30-49mm	±2.0mm
50-69mm	±3.0mm
70-100mm	±4.0mm
OVER 100mm	±5.0mm

* UNLESS OTHERWISE SPECIFIED

NOTES:

1. "*" INDICATES CABLE LENGTH IN METERS. CONTACT TURCK TO ORDER SPECIFIC LENGTH.

SOURCE DRAWING - FOR REFERENCE ONLY

RELATED DOCUMENTS 1. 2. 3. 4.	3RD ANGLE PROJECTION 	THIS DRAWING IS CONFIDENTIAL AND THE PROPERTY OF TURCK INC. USE OF THIS DOCUMENT WITHOUT WRITTEN PERMISSION IS PROHIBITED.		TURCK INC High Technology Sensors and Automation Controls 3000 CAMPUS DRIVE MINNEAPOLIS, MN 55441 1-800-544-7769 (763) 553-7300 (763) 553-0708 fax turck.com	
	MATERIAL SEE SPECIFICATIONS	DRFT KMY	DATE 04/24/12	DESCRIPTION MS 3116M-12-8P-1250-*	
	FINISH SEE SPECIFICATIONS	APVD J.B.	SCALE 1=1.5	IDENTIFICATION NO.	
	UNIT OF MEASUREMENT MILLIMETER [INCH]		DO NOT SCALE THIS DRAWING		REV B
FILE: 777028777		SHEET 1 OF 1			

B	UPDATE END VIEW SPECIFICATIONS PER ECO	KMY	01/23/13	40996
REV	DESCRIPTION	BY	DATE	ECO NO.